

8 7 6 5 4 3 2 1

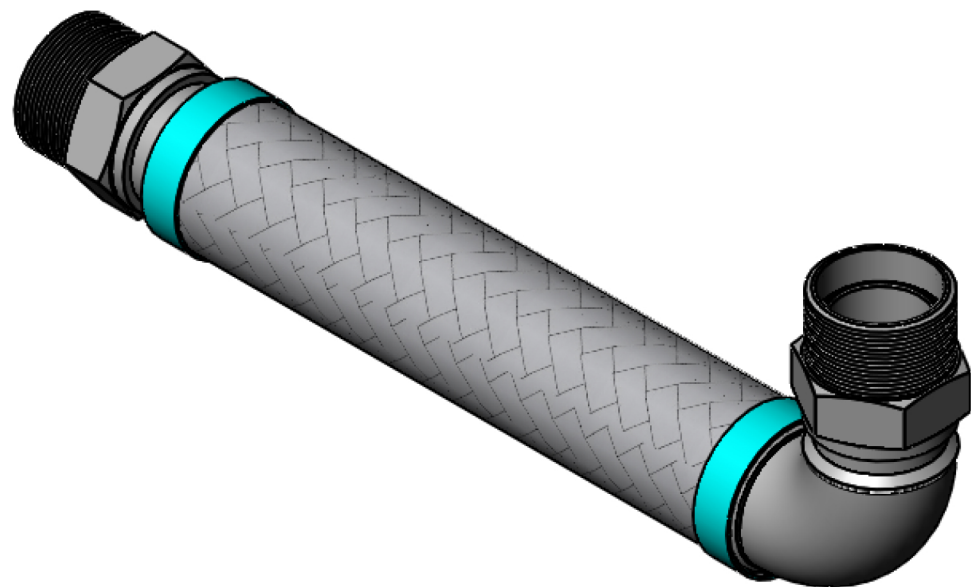
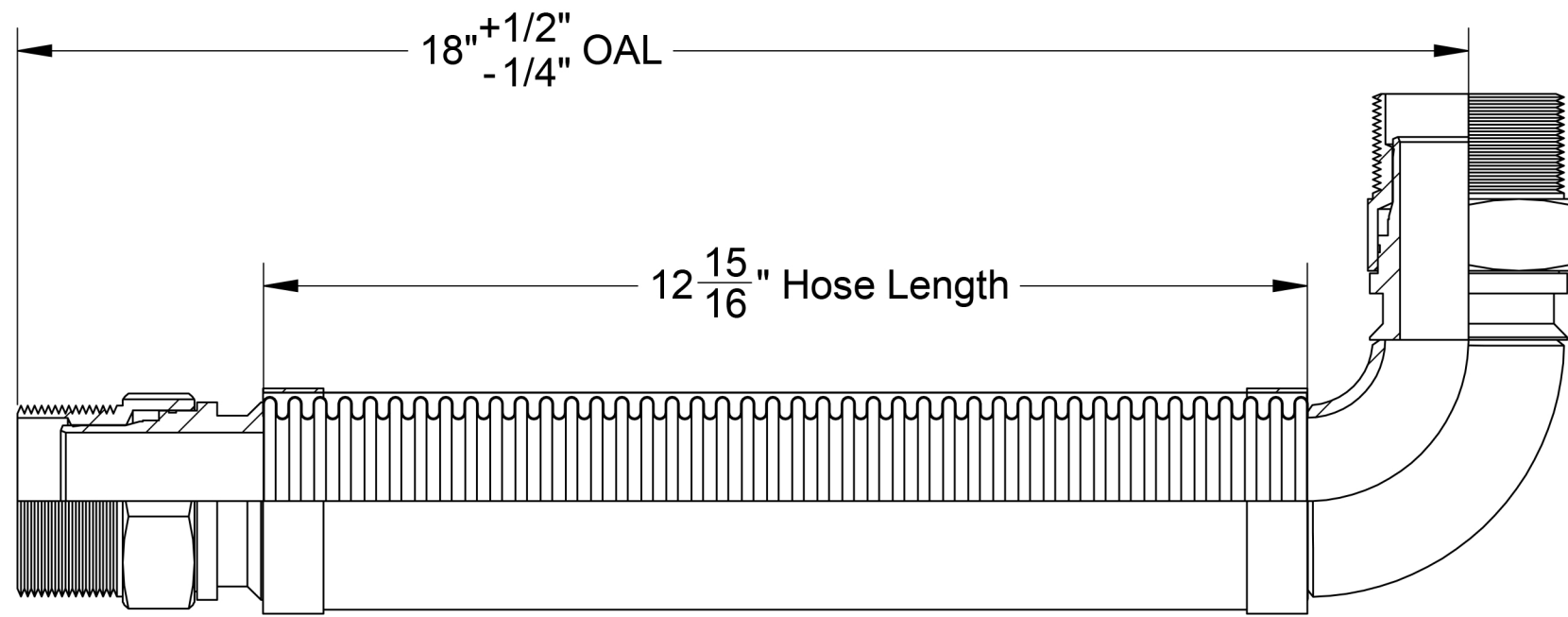

ITEM #	QTY.	PART NUMBER	DESCRIPTION	MATERIAL	WEIGHT
1	1	HOSE	300 Series Stainless HYDROFORMED Corrugated Hose	Stainless Steel	0.74
2	1	BRAID	300 Series Stainless Steel	Stainless Steel	0.06
3	2	BRAID COLLAR	0.05" Thick	Stainless Steel	0.09
4	2	2" MALE SWIVEL	2" Male Swivel, 2"x11-1/2" Thread, 2.38" Hex	Carbon Steel	0.93
5	1	2" ELBOW	2" Short Radius Elbow, Sch. 40	Carbon Steel	0.52

	HOSE MASTER Inc. 1233 East 222nd Street • Cleveland, Ohio 44117 (800) 221-2319 • Fax: (216) 481-7557 • www.hosemaster.com Locations: Cleveland • Houston		Registered to: ISO 9001 : 2000

Projection:	Customer: Hose Master Inc.	Prepared By: kannk
	Reference: Fire-Shield - 2" Male Swivel x 2" 90 Degree Male Swivel x 18" OAL	CALC. WEIGHT: 4 lbs. Date: 9/24/2009

Description: **2" ID x 18" OAL 300 Series Stainless HYDROFORMED Corrugated Hose covered by 300 Series Stainless Braid. UL Approved 2" Male Swivel Connector x 2" ID 90 Degree Male Swivel Connector**

Drawing #:	FSSSE0200x18	Rev.:	-	SHEET 1 OF 1
------------	---------------------	-------	---	--------------

REVISIONS			
REV.	DESCRIPTION	DATE	APPROVED
8		7	6

8 7 6 5 4 3 2 1